

We recommend consulting a professional if you are unfamiliar with installing hardware fixtures.

	Carlisle Brass Ltd Parkhouse Road, Carlisle, CA3 0JU
2812 - CPR - AG5228	21
EN 12209: 2003 / AC 2005	Classification

© CARLISLE BRASS

**UK
CA
1121**

Lock Information - Accreditation, Performance & Suitability for use on Fire Doors														
Item	CE Ref	Declaration of Performance	EN 12209 : 2003 classification											Intumescent Requirements FD30 & FD60 Timber Doors
			NPD	A	7	1	0	C	-	B	0	NPD	0	
BTL1	AG5228	CBB213	NPD	A	7	1	0	C	-	B	0	NPD	0	0.8mm Intercalated Graphite intumescent sheet
BTL2			NPD	A	7	1	0	C	-	B	0	NPD	0	
BTL3			NPD	A	7	1	0	C	-	B	0	NPD	0	
BTL4			NPD	A	7	1	0	C	-	B	0	NPD	0	
BTL25			NPD	A	7	1	0	C	-	B	0	NPD	0	
BTL30			NPD	A	7	1	0	C	-	B	0	NPD	0	

Preparation And Installation

Tools required: Drill & 25.4mm (1") drill bit, Mallet, Chisel, Posidrive Screwdriver, Pencil, Masking Tape

The mortise must always be aligned horizontally and vertically in order for all relevant components to operate as intended. Misalignment of any single component can lead to the breakdown of complete door set operation.

It is recommended to pilot all fixing screw locations prior to final fitting to prevent excess strain on the fixings.

Using a pencil, mark the door edge for the height and width of the mortise, and also for the forend. Use these markings as your visual guide to ensure you cut the mortise to the correct dimensions.

Using a 1" drillbit, drill the mortise accordingly, ensuring any shavings or swarf are removed and the mortise is smooth.
Note: Use tape to mark the correct depth of the drill bit. The required depth is the latch/deadbolt body length + Fixed forend + Loose Face Plate.

Insert latch body into mortise and draw around the faceplate. Chisel out to the required depth (which will include the loose faceplate).

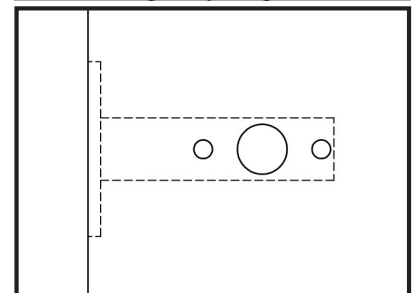
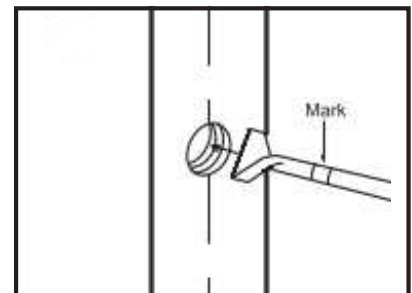
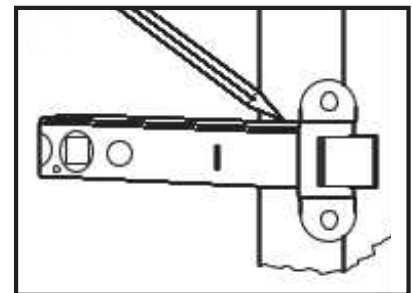

TLE TUBULAR LATCH FITTING INSTRUCTIONS

On either face of the door, mark any required hole centres for follower and accessory bolt through fixings, and drill accordingly. Remove any swarf from the mortice.

Note: *Never drill any holes while the latch is in the door.*

Insert the latch, including loose faceplate into the mortice. Ensure the bevelled face of the latch is facing the frame direction. Fix in place with included screws.

Check operation prior to preparing the frame for the strike plate.

With the latch fitted and the door in the open position, close the door gently against the frame and mark the top and bottom edge of the latch/deadbolt on the door frame.

Transfer these two marks across to the inside of the door frame rebate. Mark an additional horizontal line approximately 2mm above the top line.

This line represents the top inside edge of the aperture within the strike plate and will provide operating clearance.

Identify where the resting position of the latch will be, and draw around the strike plate accordingly.

Chisel out accordingly for the strike plate with sufficient mortice for the dust box ensuring, when fitted, the strike plate is flush with the frame.

Close door to check proper operation. Adjust anti-rattle tabs as necessary.

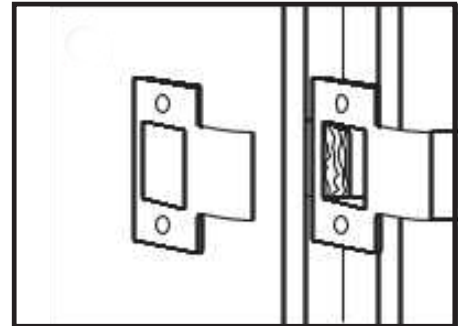
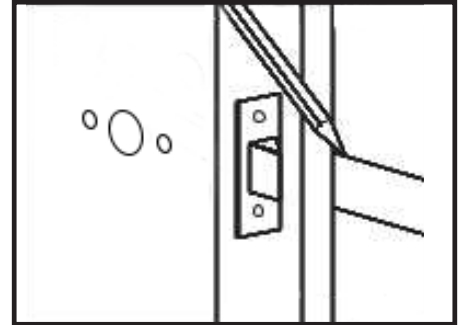
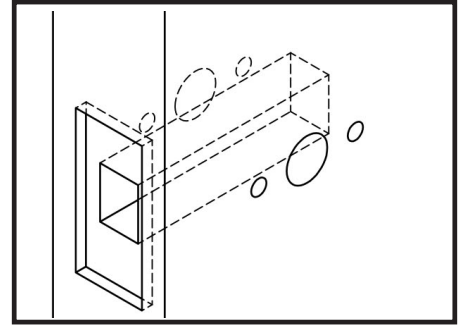

CARE AND MAINTENANCE

A care and Maintenance Schedule should be carried out regularly.

Check that the lock and the strike plate are correctly aligned and that the fixing screws are tight.

After 20,000 operations, apply fine machine oil, or GT85 (or similar) PTFE lubricant to the latchbolt and deadbolt slots, operate a few times to work the lubricant into the components, wiping away any excess. Ensure that any door or frame finishes are protected. Repeat after each additional 20,000 operations.

Declarations of Performance and other information can be downloaded from the below website and searching under knowledge centre.

<http://www.carlislebrass.com>

PLEASE LEAVE THESE INSTRUCTIONS WITH THE END USER