



DRAWING NOT TO SCALE

MALE/FEMALE FIXING SCREWS INCLUDED

Preparation: Prior to considering fixing this set of lever handles you should ensure that a suitable lock or latching device with an 8mm follower is installed in your door. We recommend the installation of a sash lock or latch with a bolt through (male/female) screws for secure fitting to the door. (fig 1)

The door should be accurately drilled at 38mm centres using an 8mm wood bit, in preparation for the fitting of the lever handles (fig 1)

The door should be accurately drilled at 38mm centres using an 8mm wood bit. The centre hole for the spindle should be drilled with a 20mm wood bit, in preparation for the fitting of the lever handles (fig 1)

Fitting: Pull off the outer rose cover from the lever handles and slide carefully off the lever ensuring that you do not damage the lever finish in the process (fig 2) Place rose covers carefully to one side in the safe place to avoid loss or damage.

Spindle: Locate the spindle on one lever, ensuring part of the spindle is adjacent to the lever grub screw on the handle until you start to feel resistance. (fig 3)

Then slowly continue to tighten the grub screw, you should feel the grub grip the outer skin of the spindle

Check against the door to make sure that the length of spindle will fit through the door and locate with the opposite lever

Bolt through operation: Insert male bolts through the inner rose and door so that they locate cleanly with female bolt from the other side. Tighten bolts ensuring that the threads do not cross. (fig 4)

Also fit the supplied wood screws to ensure the inner roses are fixed securely to the door.

Note: both male and female fixing bolts must be used. + woodscrews

To comply with performance to test criteria: Having securely fixed both levers to the door tighten the remaining grub screw into the spindle. Slide each rose cover carefully over each lever and tighten up to the face of the door. Test action of levers and adjust if necessary.

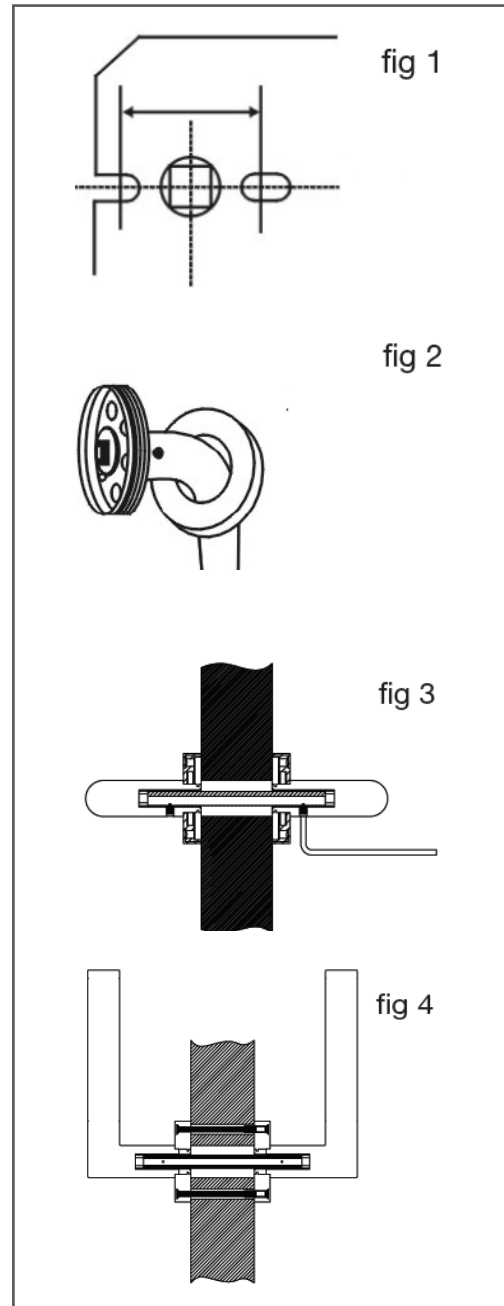

**GRADE
4
EN 1906**

FITCB0013 | January 2018